

TD-300P Horizontal Auto-Packaging Machine

((Button Knob Control Panel, Painted Finish, 6 feet In-Feed Conveyor))



** Features

1. Ergonomic design, elegant and rational, simple yet sturdy construction.
2. Smart design and easy cleaning, suitable for bakery manufacturer.
3. Independent Bottom-sealed and End-sealed temperature controller.
(**Japan OMRON** temperature Digital Controller)
4. **Servo Control Package.**
5. Wrapping speed and size can be adjusted at customers' request.
6. Easy to operate, packing size can be modified at customers' request..
7. Individual End-sealed cutting position adjustment.
>>Prevent cutting out of position product.
8. Num-pad Push Button Styles Control Panel.
9. Sanitary Modular Design.
10. All surfaces in contact with product are SUS#304 stainless steel.
11. Automatic film **Eye-Mark tracking system**, reduce empty pack and film waste.
12. Maximum width of wrapping product is 140mm.

TD-300P Horizontal Auto-Packaging Machine

Conveyor: 6 feet
(1830mm)

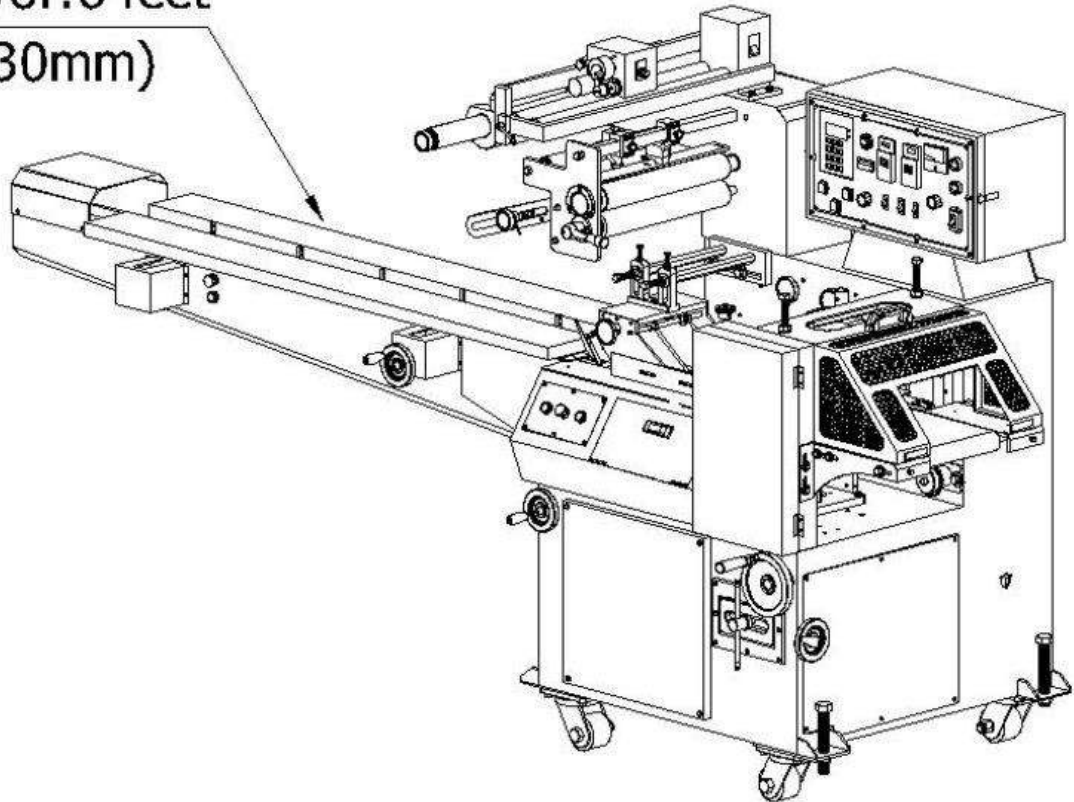

Specification:

Machine Dimensions	Length(cm)	325	Wide(cm)	100	Height(cm)	145
Machine Weight	Net Weight(N.W.Kg)	750		Gross Weight(G.W.Kg)	1050	
Electronic Features	Voltage(V)	220		Main Motor (HP)	1 (DC)	
	Frequency (HZ)	50/60		Electric Heater (KW)	2.4KW 220V	
	Servo Motor	750W ×1 220VAC				
	Control System	Electrical switch with the hided speed control button				
	Safety Device	Safety net opens electricity turn off and emergency buttons.				
Technical Features	Sealing Mode	Continuous sealing with heated crimp wheel and straight bar end seal				
	Sealing Structure	Adjustable rotating end seal bar Width 200mm				
	Sealing Style	Former, controls film & Heat melt				
	Feeding Method	In-feed conveyor		Discharge Method	Rubber belt conveyor	
	Sealing Sides	Center-seal and two end-seal				
	Packing Speed(bag/min)	25-200 ppm (Depending on packing size and film material)				
	Max. Width of Packing Material (mm)	400				
	Min. and Max. Packing Length (mm)	80 - 300				
	Min. and Max. Packing Width (mm)	30 - 140				
	Min. and Max. Packing Height (mm)	6 - 65				