

SHL-1530

Flat Surface Labeling Machine



Flat Surface Labeling Machine



Widely used in food, chemical, medical, cosmetics, electronics, hardware, automotive parts, stationery, cardboard boxes surface labeling.

Equipment composition :

Electrical cabinet, Conveyor, Separate bottle device, clamp device, Brush label device, 1# labeling engine, Operation system and control system.

Features:

- Control system: SIEMENS PLC control system, with high stable operation and extremely low failure rate;
- Operation system: SIEMENS touch screen, with Chinese and English language, rich with help function and fault display function, easy operation;
- Check system: German LEUZE check label sensor, automatic check label position, stable and convenient don't have much higher requirement for the worker skill;
- Send label system: Japan Panasonic servo motor control system, stable with high speed;
- Alarm function: such as label spill, label broken or other malfunction during machine working all will alarm and stop working.
- Machine Material: The machine and spare parts all use material S304 stainless steel and anodized senior aluminum alloy, with high corrosion resistance and never rust;
- Low voltage circuit all use the France Schneider brand.



Spare parts for ref :

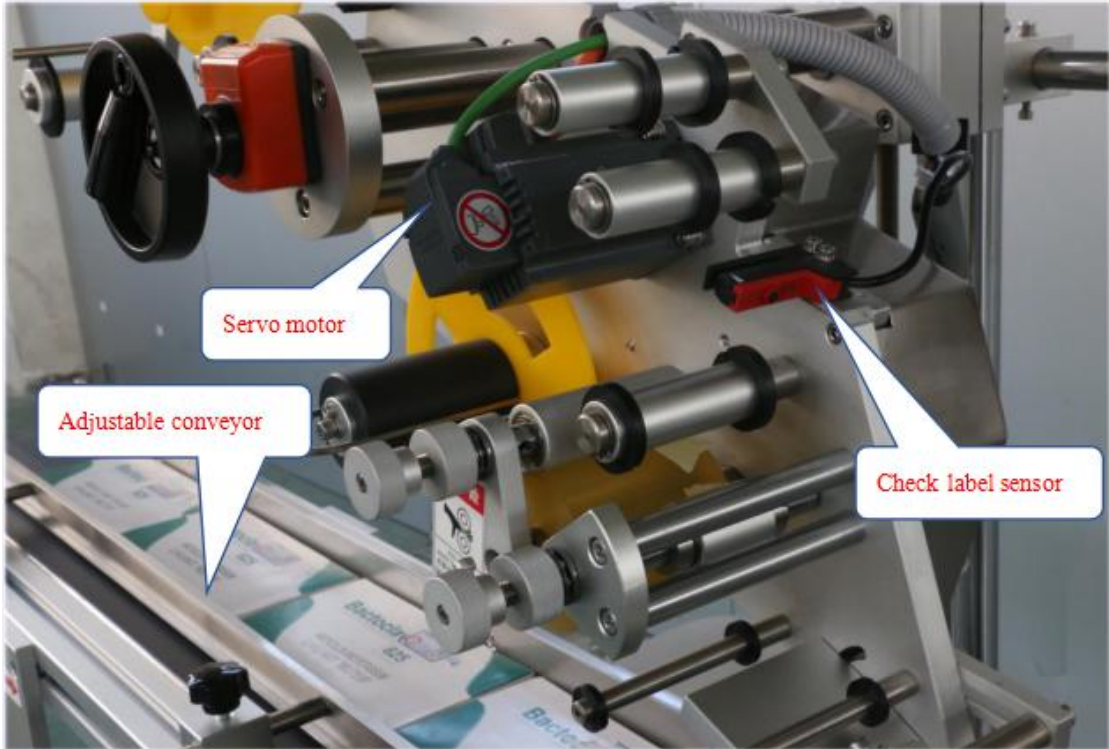

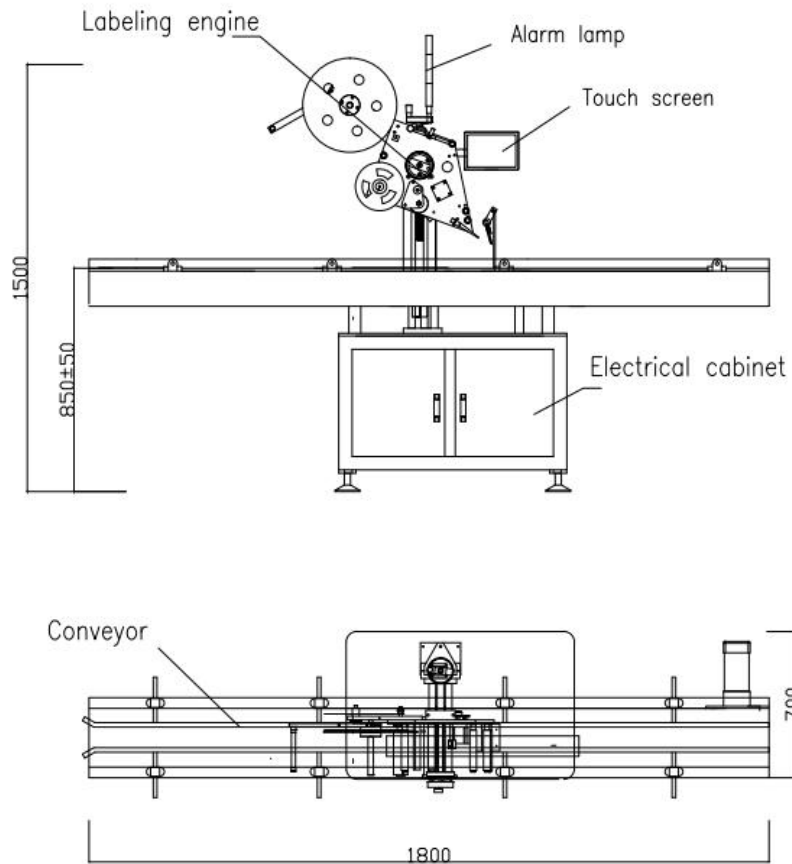

Model	SHL-1530
Driving Mode	Servo motor
Yield (pcs/min)	30-200 (depends on bottle and label size)
Operating direction	Left or Right
Conveyor Speed (m/min)	≤40
Labeling Accuracy	±1.0 mm
Inner diameter of label roll	76 mm
Outer diameter of label roll	350 mm(max)
Suitable label size	Width 10-150 mm length 10-300 mm
Suitable labeling products size	Can customized depends on client product
Printer use air	5kg/cm ²
Voltage (can customized)	110V/220V/380V
Power (w)	650W
Weight (kg)	260
Machine size	1800 (L) 800 (W) 1300 (H) mm

SaintyCo also offer:

Encapsulation Solutions

Tablet Compression Solutions

Coating Systems

Cartoning Systems

Blister Packing Solutions

