



Focus Labeling Machine

BLM-A Bottom Labeler



This machine is labeling on product bottom surface, machine conveyor with two parts, also with the clamping device to fix product not fall when labeling on the bottom.

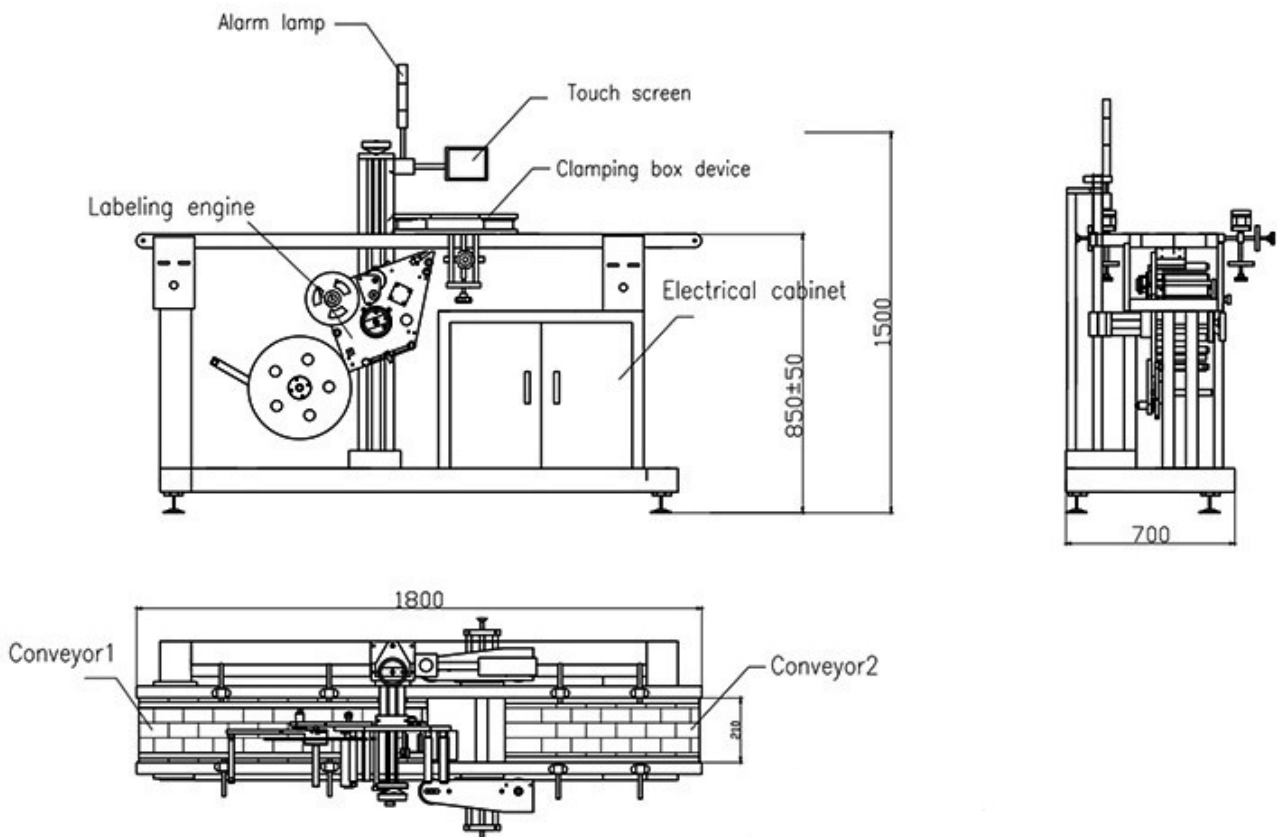

Parameters

Model	BLM-A
Driving Mode	Servo motor
Operating direction	Left or Right
Conveyor Speed (m/min)	≤40
Labeling Accuracy	±1.0 mm
The inner diameter of label roll	76 mm
The outer diameter of label roll	350 mm(max)
The suitable size of label	Width 15-300 mm length 15-300 mm
The suitable size of labeling objects	Can customized depends on client product
Voltage (In China)	AC220V 50/60HZ Single phase (Can customized as client need)