



PH SERIES

PUSHER DRIVEN SHRINK BUNDLER. Polypack's PH series shrink bundlers use main pusher and seal bar designed for wrapping individual products as well as for collating products into multipack configurations. The PH series machines are available with various infeed and collation modules. The PH series is also available with an integrated pad dispenser to create pad-supported shrink packs.

POLYPACK'S PH SERIES uses a main pusher assembly to transfer and/or collate products into the wrapping section of the machine. When necessary, Polypack uses gates, barriers and decompression plates to control the backpressure of products entering the machine, which ensures smooth product flow throughout the entire shrink wrap process.



**WE GOT IT
COVERED**



DESIGNED TO ADAPT.
BUILT TO ENDURE.
POLYPACK.COM
727.578.5000



PH SERIES

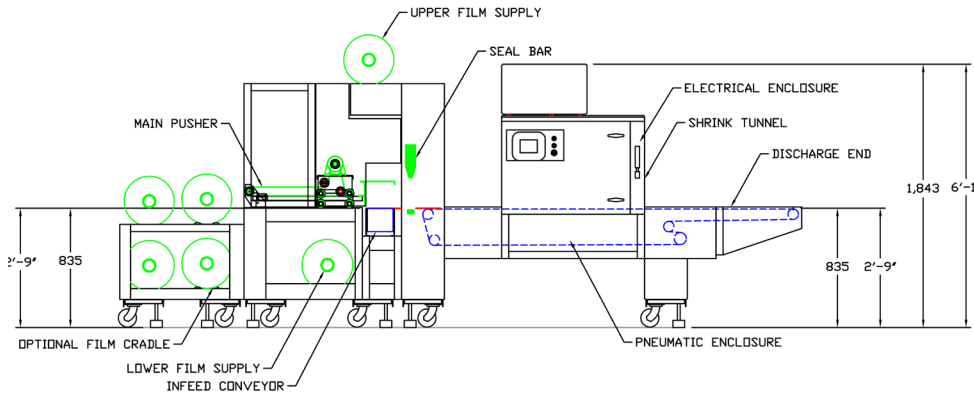
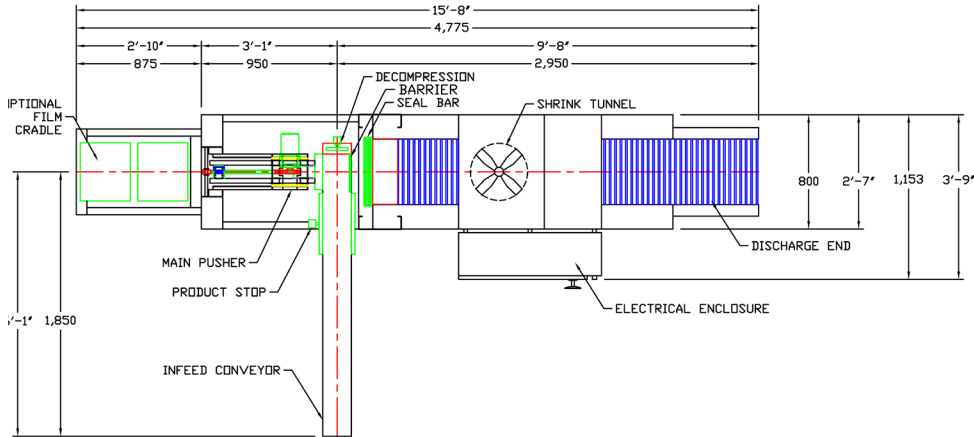

PH SERIES MACHINE FEATURES

- *Heavy Gauge, Stainless Steel Construction
- *Self-Leveling, Teflon® Coated Hot Knife Sealbar Assembly
- *Pre-Programmed Acceleration and Deceleration for Smooth Operation
- *Self-Adjusting Solid Stainless Steel Rod Tunnel Conveyor (No Belts or Coatings)
- *Engineered as a Single Unit with Integrated Double Insulated Tunnel to Reduce Energy Consumption
- *Polycarbonate Enclosures Ensure Safety and Easy Access to Machine Components
- *Quick Changeovers
- *PLC Touchscreen Interface

**WE GOT IT
COVERED**



CORPORATE HEADQUARTERS
3301 GATEWAY CENTRE BLVD.
PINELLAS PARK, FL 33782 USA

POLYPACK.COM
INFO@POLYPACK.COM
727.578.5000

