

GQCS6605S

Semi-Auto Carton Folding Sealer

半自動折蓋封箱機

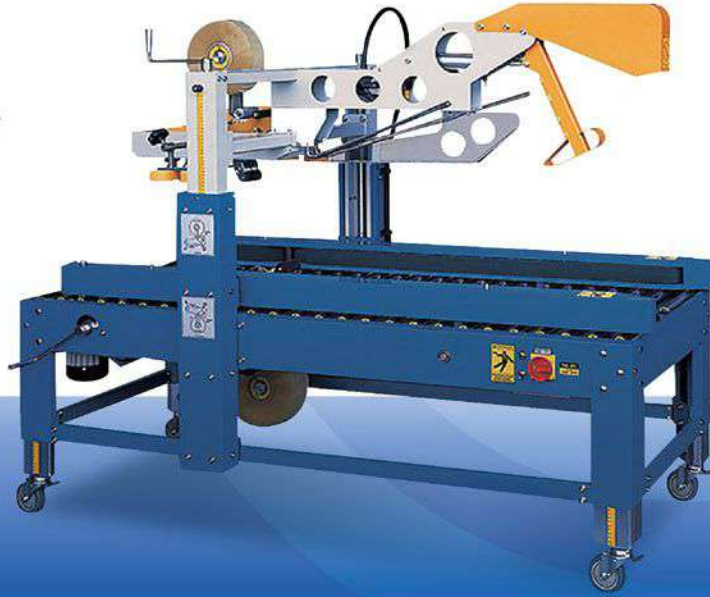

Online Video

Application

- This machine is suitable for automatic packaging lines, include top flaps folding and sealing at a time.

Key Features

- Side belt driven.
- Pneumatic top flaps folding, include front, side and rear flaps, and tape sealing at a time. Used for automatic packaging lines.
- Semi-Auto. Easy to adjust for different carton sizes by crank handle.
- Applicable to the production lines in uniform and lightweight cartons.
- Side clip-rollers make the carton sealing tight.
- Working height can be adjusted among H570~770 mm according to the front and the rear conveyors.
- Flexible top adhesive tape seat can automatically adjust for uneven cartons, which is fast, smooth and durable.
- Locking casters.
- Easy to operate.

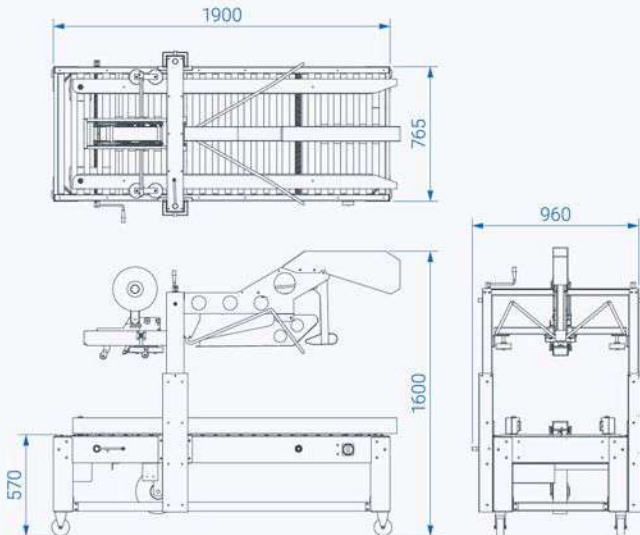

用途

- 本機適用於自動化包裝生產線，自動折上蓋、封箱一次完成。

特性

- 兩側皮帶驅動。
- 自動折上蓋，採汽缸動作，平穩順暢，封箱作業一氣呵成，省時省力，可配合自動化包裝系統使用。
- 半自動機種，附有調整手把，根據紙箱尺寸手動調整輕鬆容易。
- 適合紙箱尺寸單純生產線。適合裝載較輕產品。
- 兩側補助夾輪設計，使封箱密合度佳。
- 工作高度可配合前後傳送機作調整(H570~770 mm)。
- 上貼帶座彈性設計，可自動調整紙箱之不平，快速平整，耐用度高。
- 剎車腳輪。
- 簡易操作。

Machine Size	Driven	Tape Width	Conveyor Speed	
機械尺寸	傳動方式	膠帶寬度	輸送速度	
L1900 × W960 × H1600 mm Spec. subject to change without prior notice. 機台尺寸以實際製作為準	By Side Belt 兩側皮帶驅動	2" or 3"	20 M/min	
Tape Overlap	Working Height	2" Tape Sealing Size	3" Tape Sealing Size	Voltage
膠帶前後貼	工作高度	2" 可封箱尺寸	3" 可封箱尺寸	電壓
L60±5 mm	570~770 mm	L200~600 mm W135~500 mm W120~500 mm	L200~600 mm W150~500 mm W120~500 mm	3Φ, 220V Depend on customer's request. 可依客戶需求指定