

## *DT Series Pillow Packing Machine*

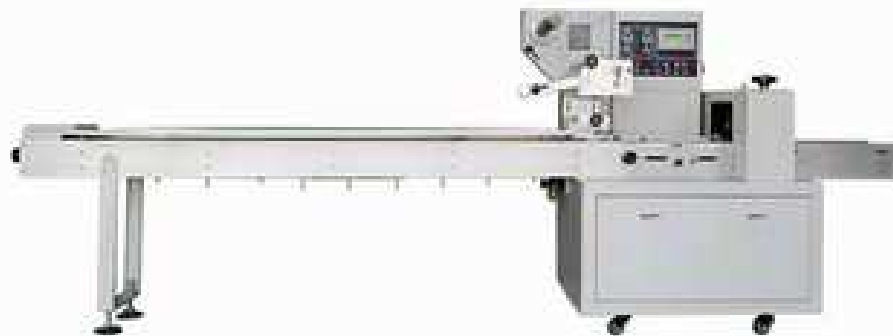

Packaging various kinds of regular objects like sugar, biscuits, pies, chocolates, bread, instant noodles, moon-cakes, drugs, daily app

### **Features:**

- Dual frequency conversion control; bag length can be set and cut in one-step, saving time and film.
- Interface features: easy to set and operate.
- Self-failure diagnosis, clear failure display.
- High sensitivity photoelectric eye color tracing, numerical input of cutting/sealing position for extra accuracy.
- Temperature independent PID control, more suitable for packaging different materials.
- Positioned stop function, without sticking knife or wasting film.
- Simple driving system, reliable working, convenient maintenance.
- All control is realized through software, easy for function adjusting and technical upgrade.

**Technical Parameters:**

<b>Type</b>	<b>DT-250</b>	<b>DT-320</b>	<b>DT-450</b>
Film width	Max. 250mm	Max. 320mm	Max. 450mm
Bag length	65-190mm or 120-280mm	65-190mm or 120-280mm	130-450mm
Bag width	30-110mm	50-160mm	50-180mm
Product height	Max.40mm	Max.40mm	Max.75mm
Film roll diameter	Max.320mm	Max.320mm	Max.320mm
Packaging speed	40-230bags/min	40-230bags/min	30-180bags/min
Power	220V,50/60HZ, 3KW	220V,50/60HZ, 3KW	220V,50/60HZ, 3KW
Dimension	3920*670*1320mm	4020*720*1320mm	4020*820*1450mm
Weight	800kg	900kg	900kg
Remark:	Optional air filling device	Optional air filling device	Optional air filling device