



# McBRADY ENGINEERING, INC.



<http://www.mcbradyengineering.com/>

1251 S. LARKIN AVE.  
JOLIET, IL 60436

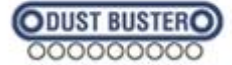

## MODEL #10 MANUAL CLEANER/RINSER

The **Model #10** is designed for economical, manual cleaning of small runs and is available as both an air cleaner and water rinser. Bottle sizes from 10ml to 4 liters are rinsed at speeds up to 30bpm. The operator inserts two bottles into the neck adapter plate where the bottles are rinsed while inverted. The operator then removes the cleaned bottles and places them onto the filling line.



### Special Features

- **Direct tube injection** of air, water, or chemical
- Adjustable rinse cycle timer allows for a **timed liquid and air rinse** of bottle's interior
- Customizable to accommodate a multitude of different size bottles, anything from **1oz to 5 gallons**
- Stainless Steel Cabinets with viewing flap **protect operators from any accidental water splash**
- Type 304 Stainless Steel and FDA approved plastic construction

MEMBER



# SPECIFICATIONS

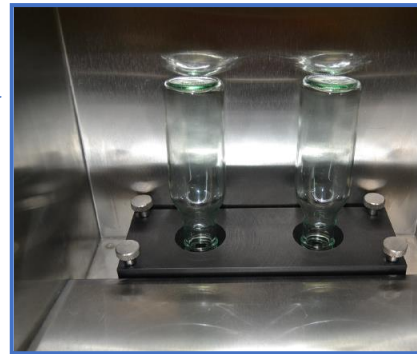
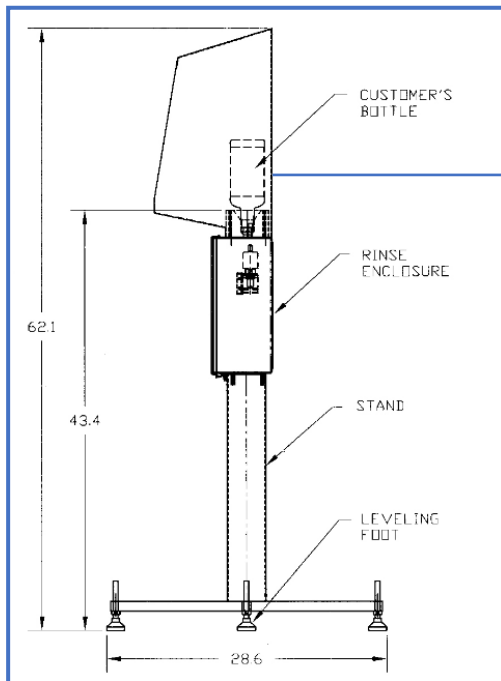
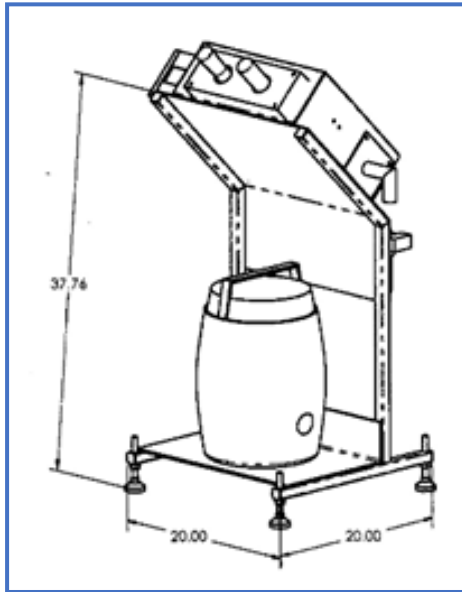

## OPTIONAL ITEMS

- Automatic Air Flow Activation
- Timed Rinse Cycles
- Recirculation Pump
- Air Ionizing Kit
- Attachable Dust Collector with HEPA filter
- Rolling casters for mobility
- Type 316 Stainless Steel Construction