

電熱收縮爐

ELECTRIC HEAT TUNNEL

適用

用於收縮膜料套在瓶罐上，收縮爐溫度可控制，且可搭配不同輸送帶於線上生產，快速移動和更換生產線。

特點

- 主機結構為不銹鋼材質隔熱板。
- 數位溫度顯示控制附加矽控整流 (SCR) 設計。
- 熱出風口採不銹鋼插板插入特殊設計方便調整。
- 分離式電控箱。

APPLICATION

It is used to shrink sleeve labels onto bottles, the tunnel offers flexible control of temperature. The heat tunnel can be moved to different production lines with simplicity and speed.

FEATURES

- Stainless steel construction with heat insulation panel.
- Digital temperature display controller designed with SCR (silicon control rectifier) constant temperature device.
- The air outlet adopts special design with flashboard insert, and easy adjustment.
- Independent control cabinet.



蒸氣收縮爐

STEAM SHRINK TUNNEL

適用

用於收縮膜料套在瓶罐上，適用各種瓶型和尺寸，客戶需自備蒸氣鍋爐。

特點

- 機台主要結構為不銹鋼製成。
- 可依收縮位置調整蒸氣管之寬度與高度。
- 可拆式門，易於調整蒸氣管。
- 數位溫度顯示器。
- 最大蒸氣量 250 公斤 / 小時。
- 蒸氣壓力 3 到 5 kg。

APPLICATION

It is used to shrink sleeve labels onto bottles, suitable for all shapes bottles and all types of shrink films from PVC to OPS.

FEATURES

- Stainless steel construction.
- The width and height of the steam pipe is adjustable by the shrinking position.
- Access doors to adjust the steam pipes.
- Digital temperature display.
- Maximum steam volume: 250 kg/hour.
- Steam pressure: 3 to 5 kg.



克維特有限公司

KWT Machine Systems Co., Ltd.

E-mail: sales@kwt.com.tw

http://www.kwt.com.tw

總公司 || MAIN OFFICE

41161 台中市太平區太平21街21號

NO.21, Taiping 21 Street, Taiping Dist, Taichung City 41161, Taiwan

TEL: +886-4-2277-3390 FAX: +886-4-2277-3412

桃園辦公室 || TAOYUAN BRANCH

33862 桃園縣蘆竹鄉上興路377號

NO.377, Shangxing Rd., Luzhu Township, Taoyuan County 33862, Taiwan

TEL: +886-3-323-3359 FAX: +886-3-323-3259

上海分公司 || SHANGHAI BRANCH

215412 江蘇省太倉市陸渡鎮萬金北路11號

NO.11, Wanjin North Road, Ludu Town, Taicang City 215412,

JiangSu Province, P.R.C. TEL: 0512-53455208

Emal: kwtpack@kwtpack.com.cn Website: www.kwtpack.com.cn

營業項目：

1. 理瓶機
2. 洗瓶機
3. 液體充填機
4. 鎖蓋機
5. 貼標機
6. 熱熔膠薄膜貼標洗瓶機
7. 套標機
8. 整廠規劃

BUSINESS ITEMS:

1. Bottle Unscrambler
2. Bottle Rinsing Machine
3. Auto Filling Machine
4. Auto Capping Machine
5. Labeling Machine for Adhesive Labels
6. Roll-Fed Labeling Machine
7. Shrink Sleeve Labeler
8. Complete Line Solutions



克維特有限公司
www.kwt.com.tw



KWT-1500 收縮膜套標機

SHRINK SLEEVE LABELER



適用

KWT-1500 系列套標機適用於瓶口、瓶身中間定位、瓶身到底及整瓶套標，產能可達到 100 瓶 / 每分鐘。

特點

- 本機主要結構由不銹鋼和鋁合金製成。
- 安全外罩降低工安因素。
- 人機介面控制系統，操作簡便。
- 50 組記憶區，容易操作且能夠迅速更換產品。
- 18" 動力送料托盤。
- 套標驅動機構由三菱伺服馬達控制。
- 切刀機構搭配三菱伺服馬達，以確保準確度。
- 可與生產線連線作業。
- 模組化設計，快速更換瓶型。

選項

- 輸送帶整合。
- 電熱收縮爐或蒸氣收縮爐。
- 預縮機構。
- 沖孔機構。

規格 SPECIFICATION

型號	Model	KWT-1500
機械尺寸	Machine Dimension	L: 1800 x W: 1000 x H: 2100 mm
產能	Output Speed	100 BPM (Dependent upon cut length and product size.)
瓶子直徑	Bottle Diameter Range	25 - 155 mm
套標長度	Sleeve Length Range	30 - 300 mm
標籤厚度	Label Thickness Range	40 - 50 Micron
標籤捲尺寸	Roll Capacity	O.D.: 18", I.D Core: 5 - 10"
膜料材質	Material	PVC / PET / OPS
動力消耗	Power Consumption	2.5 KW

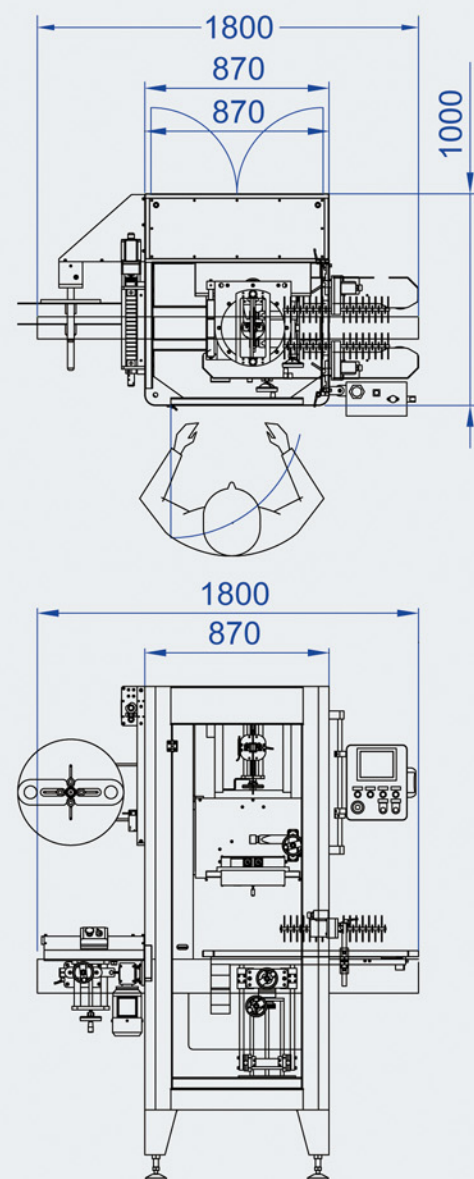

APPLICATION

The KWT-1500 shrink sleeve labeler is a fast, efficient and easy-to-operate. The labeling system can handle tamper-evident, overall, middle, and full-body sleeve applications. The KWT-1500 allows for production rates up to 100 products per minute, it will easily handle a wide range of container shapes and sizes.

FEATURES

- Robust stainless steel and anodized aluminum construction.
- Safety guard provides the operator protection during labeling.
- HMI touch screen ensure user-friendly operation.
- 50 programmable product profile presets.
- 18" powered label unwind.
- Shrink driving device: Mitsubishi servo motor.
- Cutting assembly equipped with Mitsubishi servo motor for high accuracy.
- Easy to operate settings and easy product changeovers.

OPTIONS

- Integrated conveyor.
- Electric or Steam heat tunnels.
- Pre-Shrink device.
- Perforation device.
- Consult factory for others.

標籤套入位置

LABEL LOCATION

