



Focus Labeling Machine

UDPM-A Top & Bottom Labeler



1. Model: UDPM-A
2. Brand: SKILT
3. Labeling objects: bottle, carton, box, bags, container
4. Label material: adhesive sticker
5. Power (W): 1100
6. Labeling speed (pcs/min) : 10-100pcs/min
7. Control system: America AB
8. Operation system: BGCS
9. Machine size (L*W*H): customized

Labeling on bottle, carton, bags, container top and bottom two sides at the same time in food, medicine, daily chemical and other industry. Machine conveyor specially made for two parts, with the clamping device fix object not fall off when labeling.

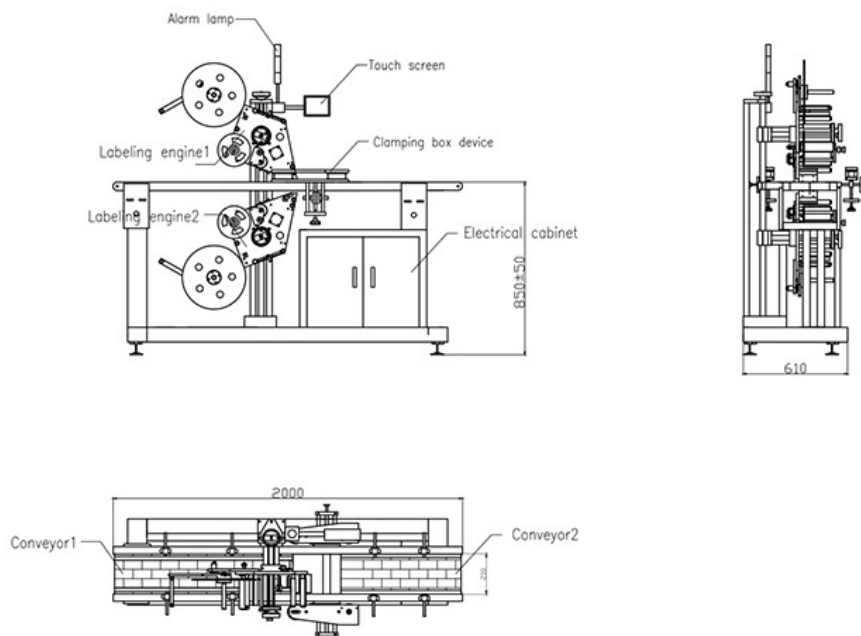

Parameters

| Model | UDPM-A |
|---------------------------------------|---|
| Driving Mode | Servo motor |
| Yield (pcs/min) | 10-100 |
| Operating direction | Left or Right |
| Conveyor Speed (m/min) | ≤40 |
| Labeling Accuracy | ±1.0 mm |
| Label material | Adhesive sticker, opaque or transparent label |
| The inner diameter of label roll | 76 mm |
| The outer diameter of label roll | 350 mm(max) |
| The suitable size of label | Width 15-300 mm length 15-300 mm |
| The suitable size of labeling objects | Can customized |
| Printer use air | 5kg/cm ² |
| Voltage (In China) | AC220V 50/60HZ Single phase (Can customized as client need) |