

# P harma Bin

## LDZ Series



## Pharma Bin

### To use with HZD, HDD Bin Blender

**LDZ** Series Pharmaceutical Bin is one of the most popular shifting containers used in the producing flow of solid dosage. It can be used along with HZD series Bin Blender, HDD series Bin Blender, etc. Different processing crafts for solid materials can be operated in the same container. The frequent charging and discharging of materials are reduced thus avoiding dust and cross pollution. It' s conformity with GMP requirements.



**Features:**

It's made of Austenitic stainless steel. All Angles are cambered. There is no dead angle, con concave-convex face and no screw on surface. The surface outside and inside are polished to high quality. Roughness degree inside is  $Ra = 0.2 \mu m$ , and outside is  $Ra = 0.4 \mu m$ . Applying sealing appliance made of silicon latex on the cover to gain a good airproof quality. Tailor-made butterfly valve with no dead angle, no remnant, or appliance against wrong way operation is easy to dismantle and clean. It's in conformity with GMP requirements.

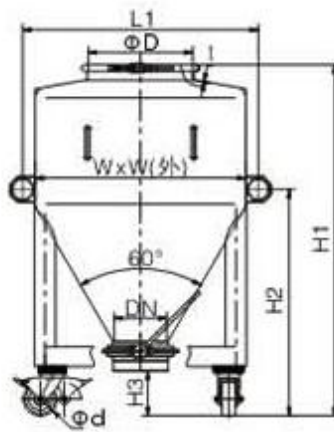
**Dimensions:**

Parameters	Volume	Main structural dimensions							Weight
	L	H1	H2	H3	ØD	Ød	W1	DN	kg
<b>LDZ300</b>	300	1118	960	138	400	125	794	200	145
<b>LDZ400</b>	400	1287	1130	165	400	125	794	200	155
<b>LDZ600</b>	600	1366	1200	151	500	125	994	200	185
<b>LDZ800</b>	800	1545	1375	118	500	125	994	200	200
<b>LDZ1000</b>	1000	1586	1400	168	500	150	1194	250	248
<b>LDZ1200</b>	1200	1736	1550	181	500	150	1194	250	285
<b>LDZ1500</b>	1500	1868	1680	99	500	150	1194	250	312
<b>LDZ1800</b>	1800	1982	1800	141	500	150	1194	250	328
<b>LDZ2000</b>	2000	2238	2055	113	500	150	1194	250	355

SaintyCo also offer:

Encapsulation Solutions

Tablet Compression Solutions

Coating Systems

Cartoning Systems

Blister Packing Solutions

