

ID TECHNOLOGY®

L&C

LABELING
& CODING

ROTARY LABELING SYSTEMS MODULAR PLUS 540 & 770

Dependable, Flexible,
Pressure Sensitive Labelers



FEATURES & BENEFITS

- High speed labeling - max outputs from 140 - 180 containers per minute
- Line layout compatibility - both clockwise and counter clockwise versions are available.
- Multiple labeling station configurations - each model can be built with 1, 2, 3 or 4 labeling heads.
- Flexible - servo driven bottle plates allow programmed, recipe driven container control.
- Fast, simple changeovers - tool-less quick release change parts.
- Repeatable set-ups - 5-axis labeling head adjustment with dial indicators ensures quick and repeatable set-up for each labeling head.
- Easy access for maintenance and changeover - small footprint, with rounded frame design makes it easy to access the machine components.
- Schneider PLC and VFD controls.
- Panel PC HMI for complete system control.
- Feedscrew infeed control with bottle stop.
- Ergonomic "lift" safety guarding.
- Nationwide service and support by ID Technology technicians.

Prearranged Options

- Laser, TTO or inkjet coding for adding variable data.
- Electronic container orientation.
- Label inspection system.

US Based Facility

- Change parts design & manufacturing, machine final assembly, testing & FATs all accomplished at our plant in Cincinnati, OH. This ensures faster than industry standard deliveries - often in 6 to 8 weeks!.

Machine Model	Modular Plus 540-6T-SM	Modular Plus 540-9T-SM	Modular Plus 770-10-SM
No. of Pressure Sensitive Stations	2 included with the ability to add a 3rd	2 included with the ability to add a 3rd	2 included with the ability to add two additional stations
No. of Bottle Plates	6	9	10
Pitch	283 mm	188.4mm	241.8mm
Run Speed/Max Speed	97 BPM - 110 BPM	117 BPM - 133 BPM	155 BPM - 183 BPM
Label Roll Ø	400mm	400mm	400mm
Min/Max Label Height	20 - 200mm	20 - 200mm	20 - 200mm
Min/Max Label Length	15 - 480mm	15 - 480mm	15 - 480mm
Min/Max Container Height	120 - 355mm	120 - 355mm	120 - 355mm
Min/Max container Ø	40 - 120mm	40 - 120mm	40 - 120mm
Max shaped container size	85 x 120mm	85 x 120mm	85 x 120mm

MODULAR PLUS 540

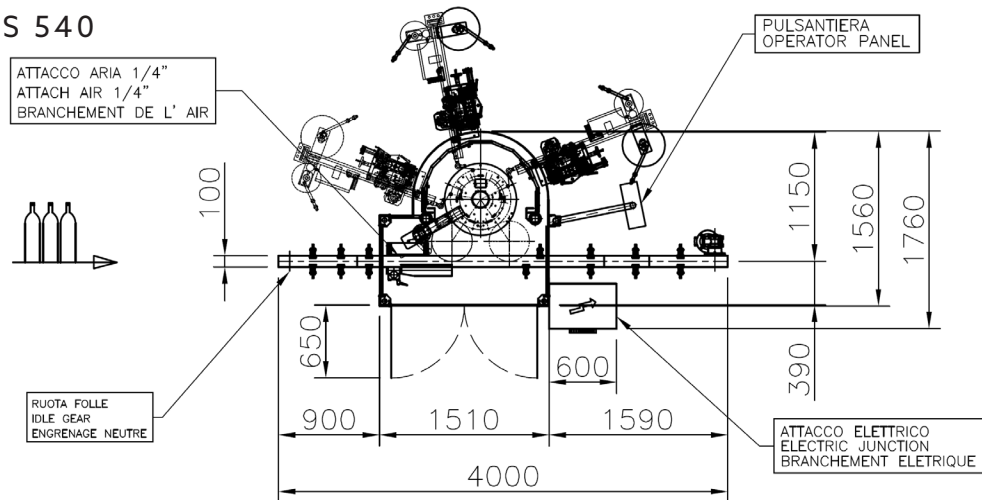

MODULAR PLUS 770

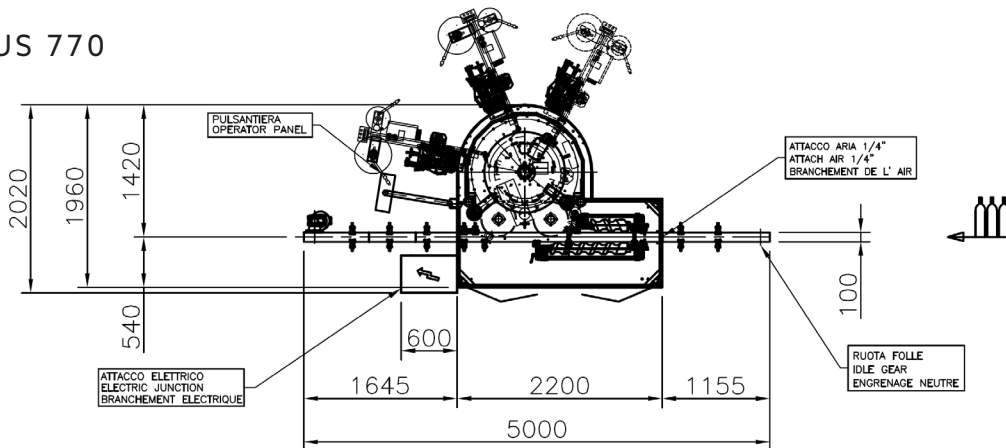

©2018 ProMach Inc. ProMach reserves the right to change or discontinue specifications and designs shown in this brochure without notice or recourse
RotaryLabelers-SpecSheet