

Horizontal Automatic Packaging Machine

SDXD-11



Horizontal Automatic Packaging Machine

The **SDXD-11** can pack powders, granules, liquids, pastes and so on with the mode of three side or four side sealed sachets. It is the packaging machine in foodstuff, pharmaceutical and cosmetic industry which is your best choice.



Features:

- Up to 90 pouches/min.
- Producing speed is high.
- Changing the size is easy.
- Product's package is beautiful, and the sealing site is not stained with fluid or powder, so the package is firm.
- Wrapping Material: All kinds of multilayer heat-sealable films.

Volumetric Cup Filing Device
(Granule)



Auger Filler Device
(Powder)



Gravity Dosing Device
(Liquids)

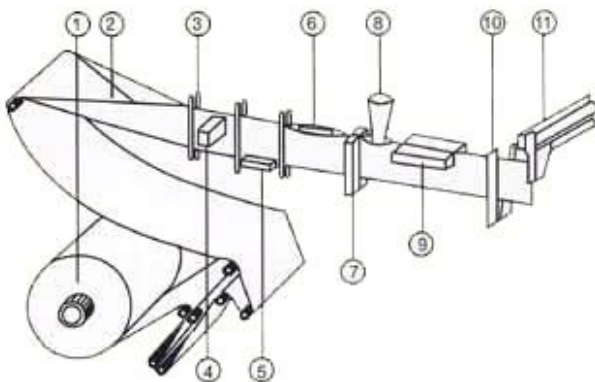

Piston Pump Filling Device
(Creams and Pastes)

**Work Flow:**

1. Reel of material
2. "V" Formation
3. Folding guides
4. Optical sensor
5. 4TH seal
6. Opener
7. Vertical sealing jaws
8. Discharge funnel
9. Upper seal
10. Scissors
11. Pulling fingers

Dimensions:

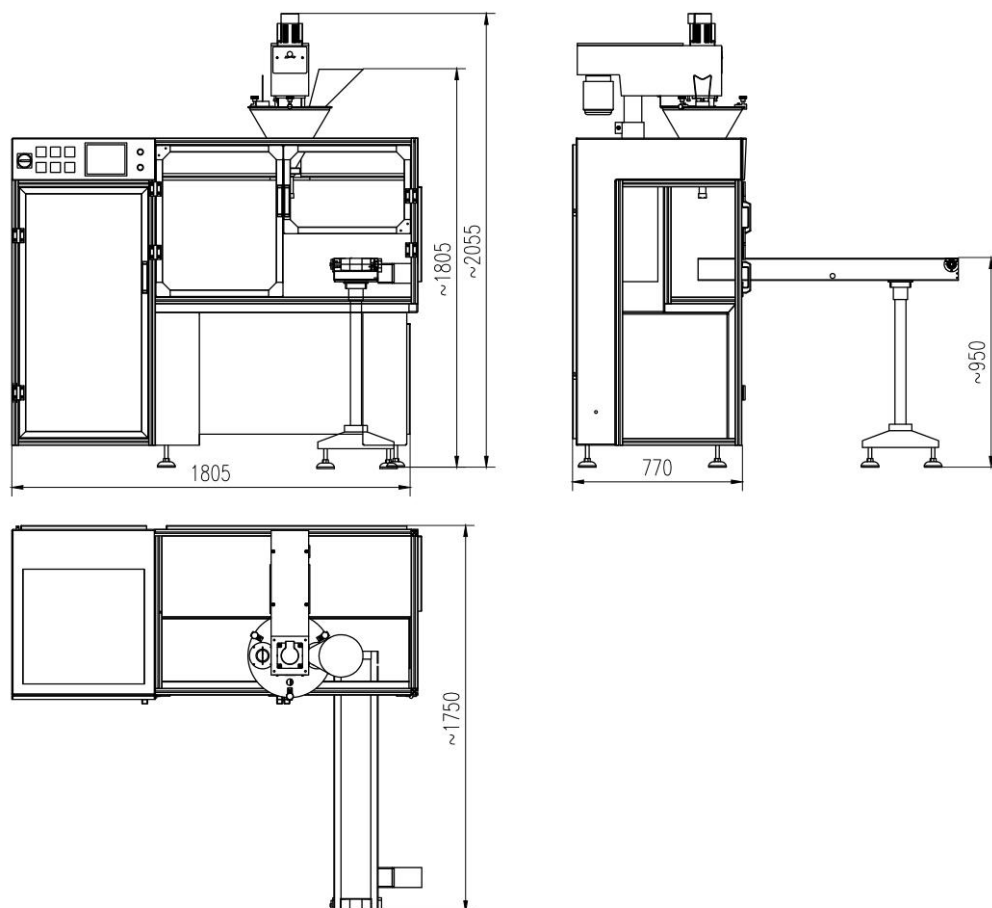

Technical Data	SDXD11
Size range of sachet	50×50~110×130mm
Volume	2.5~60ml
Output	40-90pouches/min
Consumption	1.9KWA
Weight	450kg
Dimensions	1805×770×2055mm(L×W×H)

SaintyCo also offer:

Encapsulation Solutions

Tablet Compression Solutions

Coating Systems

Cartoning Systems

Blister Packing Solutions

