

SHL-3510

AUTOMATIC SIDE LABELING MACHINE



AUTOMATIC SIDE LABELING MACHINE



Suit for round,flat,square,cone shape products in cosmetic, food, pharmaceutical and other light industries,with one label on product one side or more different sides.

Operation control system:

World famous brand PLC and servo system, multifunctional man-machine interface operation, production count, visual monitoring of parameter adjustment, help function and fault display show function; can preset many group labeling parameters; change bottle no need re-setting;Detect label length automatically.

Features:

- The whole machine and spare parts use international standard S304 stainless steel imported alloy material; double anodic oxidation treatment, with high corrosion resistance and never rust, suit for any production environment.
- German import labeling engine is optional, advanced self-adaption labeling control system, reduce and simplify operating and adjusting, improve efficiency; After change products or label, made simply adjustment is ok, don't have much requirement for worker skill.
- Press bottle device use special elasticity top press device and famous servo motor, make sure product not move keep in one line when labeling.
- Tidy bottle device use synchronous double chain for correction, stable and accurate.
- Labeling engine angle can adjust with a wide scope, also suit for cone bottle and multi sides bottle labeling.

Optional:

- Thermal transfer printer(TTO) or ink jet coding is optional.
- Opaque or transparent label material all ok.
- Also can add device suit for round bottle wrap around.

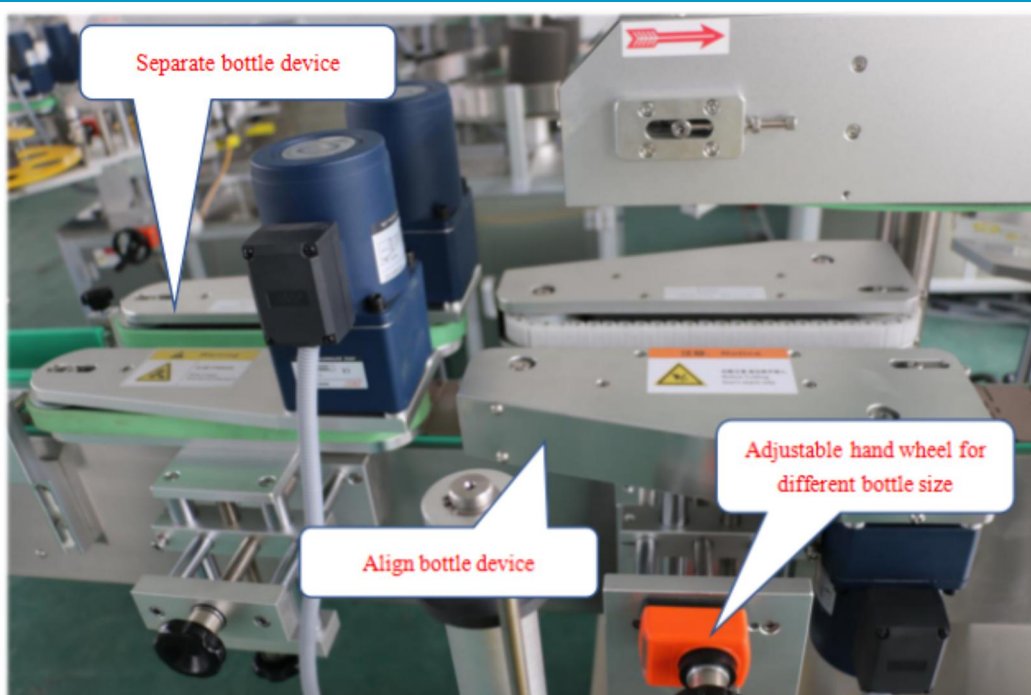

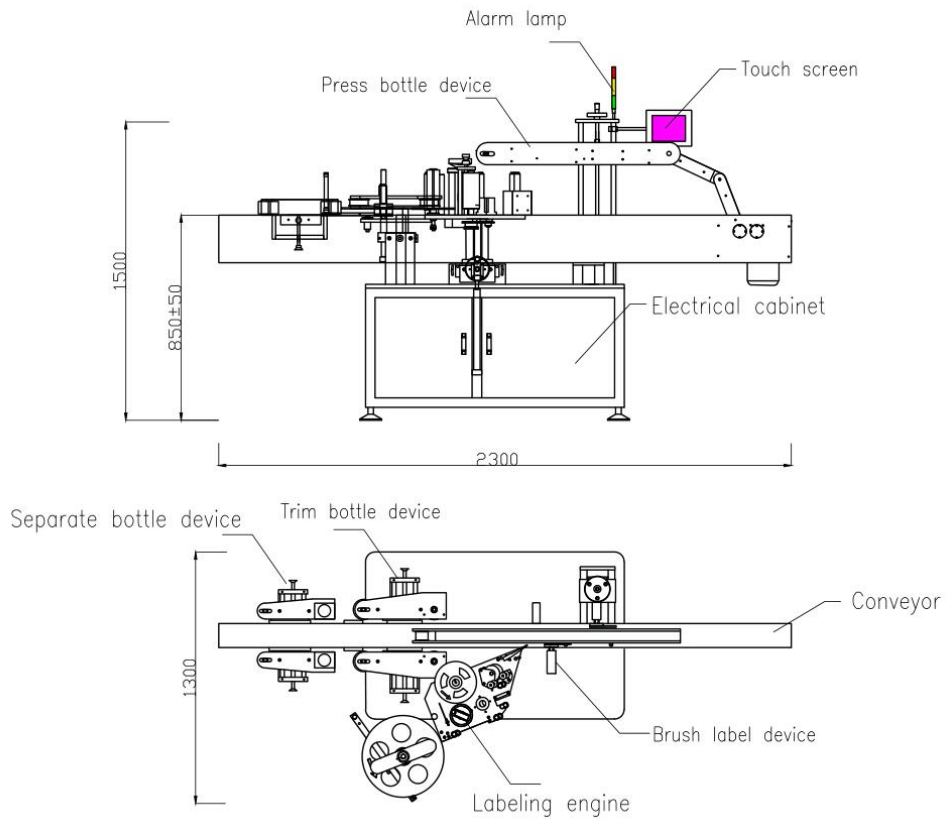

Technical Data	SHL-2520
Labeling speed	30-180 (depends on bottle and label size)
Label objects size	(square/flat bottle) Thickness 20-100mm, Height ≤ 320mm (round bottle) Diameter Ø20-90mm
Label size	Length 10-200mm, Height 10-140mm
Labeling accuracy	±1.0mm
Label roll diameter	Inner diameter: 76mm , Outer diameter: 350mm
Air pressure	0.6Mpa
Power supply	220V, 60Hz, Single Phase, 1.6Kw
Dimensions	2300x 1300 x 1500mm
Weight	360Kg
Conveying direction	Left or Right

SaintyCo also offer:

Encapsulation Solutions

Tablet Compression Solutions

Coating Systems

Cartoning Systems

Blister Packing Solutions

