

Model : SUS 101 - MHW

Application

Snacks

Bulk candies

Rice

Pulses

Pasta & Biscuits etc . . .

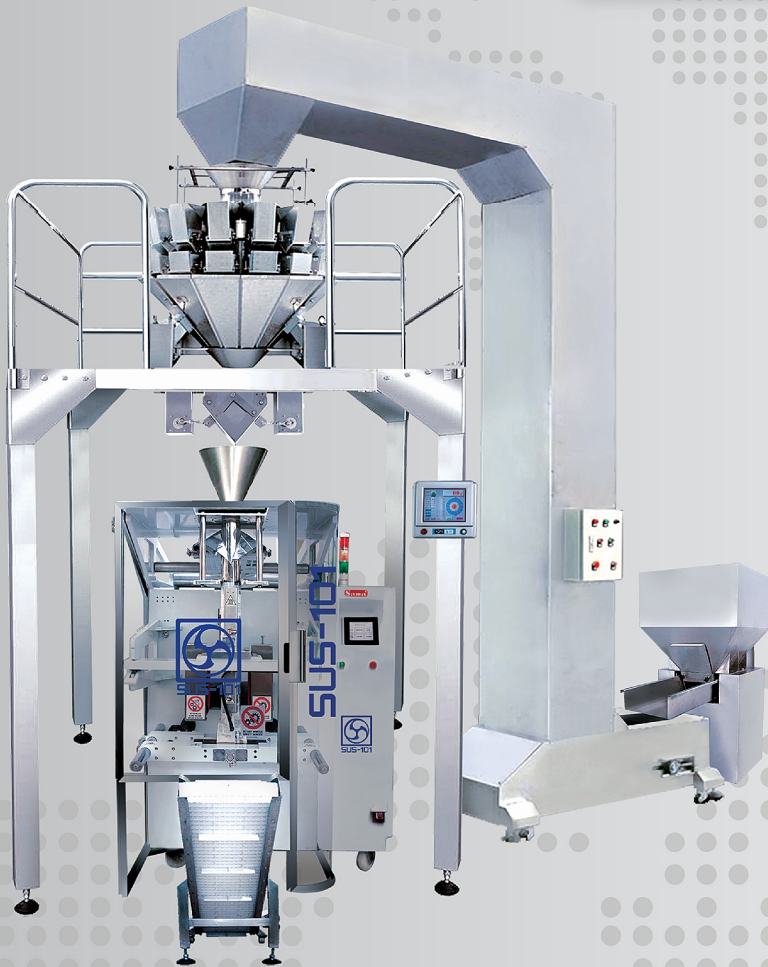

Detergents & granules substances

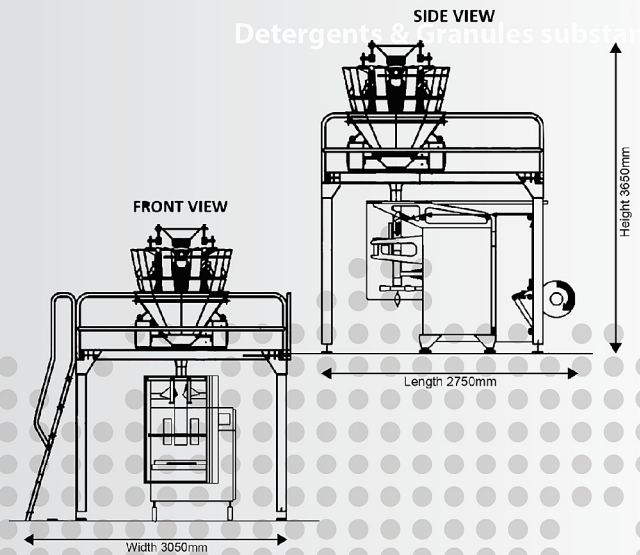

Technical Specification

- Speed ----- 60-90 BPM (depends on Product and paper characteristics).
- Bag Shape ----- Optional
- Feeding Systems ----- Multi Head Weigher
- Film ----- Any Heat sealable
- Power Supply ----- 400v 50Hz Three Phase.
- Total Power Energy ----- 4.5 K-W
- Max. Reel Dia x Width ----- 300 mm
- Dimension ----- L 2200 x W 1120+600 x H 1800 mm
- Core Bore ----- 76 mm
- Air ----- 6 - 8 bar

