

MICROSTACK™

*ULTRACOMPACT
PALLETIZER*



Palletizing at a Fraction of the Size.

KEY FEATURES

- ▶ Compact footprint makes the most of your floor-space.
- ▶ Fast operation capable of handling up to 50 cases/minute and 5 picks at a time.
- ▶ Preset pattern recipes allow for quick changeovers.
- ▶ Safe and easy to operate.
- ▶ Buffering system during pallet change.

TECHNICAL SPECIFICATION

OVERALL DIMENSIONS	L: 106" W: 58" H: 75"
INFEED HEIGHT	47"
PALLET HEIGHT	Up to 52"
CASE SIZE RANGE	L, W, H Range: 3-12"
SPEED	Up To 50 Cases/Min.

PALLET LOADING & UNLOADING



BUFFER STATION

LINEAR GANTRY PICKER

MICROSTACK™

CASE INFEED CONVEYOR

SIDE VIEW

FRONT VIEW

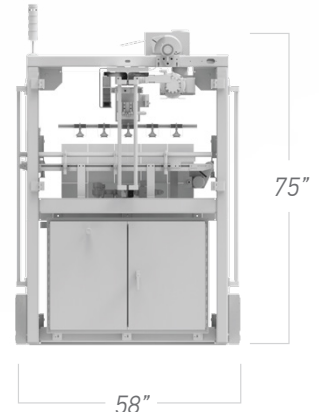
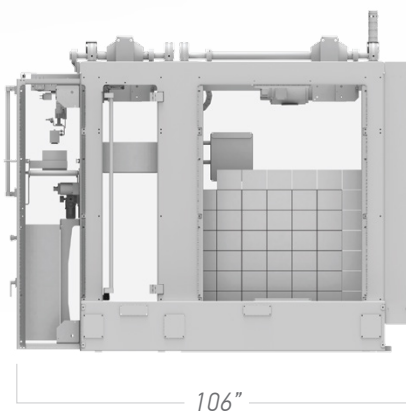

THE NORTECH GUARANTEE

All NorTech Packaging Machines Come Standard With:

- ✓ Fast Delivery and Global Service Support
- ✓ Detailed Manuals and Documentation
- ✓ Complete Spare Parts Support