

MODEL 590

Semi-Automatic Bucket Label Applicator



 auto labe

MODEL 590

Semi-Automatic Bucket Label Applicator

Auto Labe's Semi-Automatic Bucket Labeler is ideal for labeling empty 2.5 to 6 gallon buckets and is perfect for small production runs. This labeler can use pre-printed labels or be married with a table-top printer for Print and Apply capabilities. Built to last with only the best components for maximum versatility and performance.

FEATURES		SPECIFICATIONS	OPTIONS
<ul style="list-style-type: none"> • Foot Pedal Activated • Stainless Steel Top • Heavy Duty Construction • Caster Mounted • Easy Operation 	<ul style="list-style-type: none"> • Label Orienting with PLC • Front & Back Labeling • LCD for PLC Control • Emergency Stop Switch 	<p>Air Requirements: 3 CFM @ 90 PSIG</p> <p>Electric Requirements: 110 VAC 60 HZ/5 AMP 220 VAC 50 HZ (Optional)</p> <p>Equipment Weight: 370 lbs/168 kg (approx.)</p>	<ul style="list-style-type: none"> • Hot Stamp Imprinters • Print & Apply Loose Loop

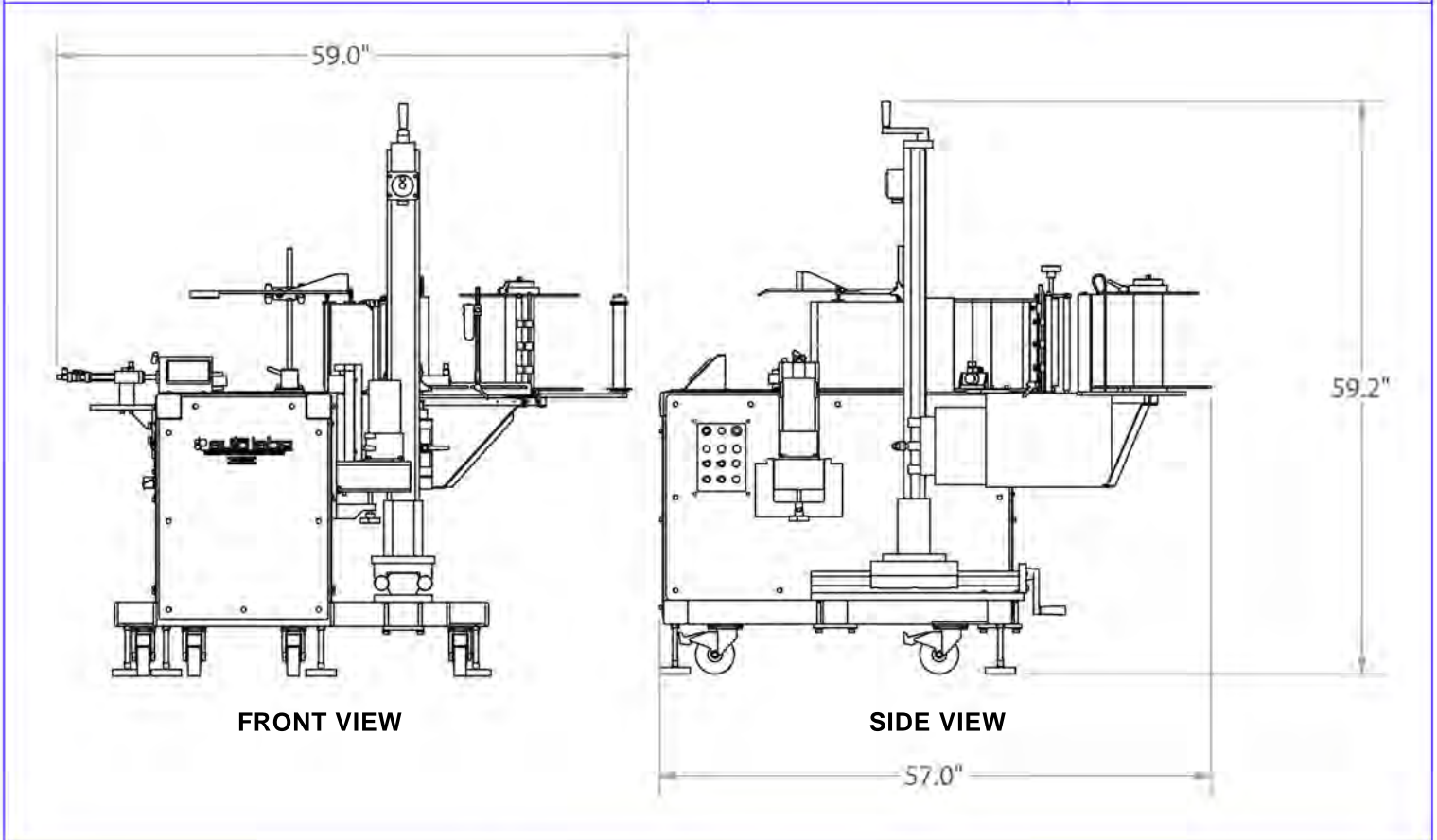

DIVISION OF BOOTH MANUFACTURING COMPANY

3101 Industrial Avenue Two, Fort Pierce, Florida 34946
 Toll Free 800-634-5376 • 772-465-4441 • Fax 772-465-5177
www.autolabe.com • email: info@autolabe.com