



Focus Labeling Machine

DPM-S Top Two Stickers Labeler



1. Model: DPM-S
2. Brand: SKILT
3. Labeling objects: box, carton, bags
4. Label material: adhesive sticker
5. Power (W): 1000
6. Labeling speed (pcs/min): 10-80pcs/min
7. Control system: America AB
8. Operation system: BGCS
9. Machine size (L*W*H): customized

With two labeling engines on machine conveyor, satisfied client labeling requirement on project surface with two stickers one by one.

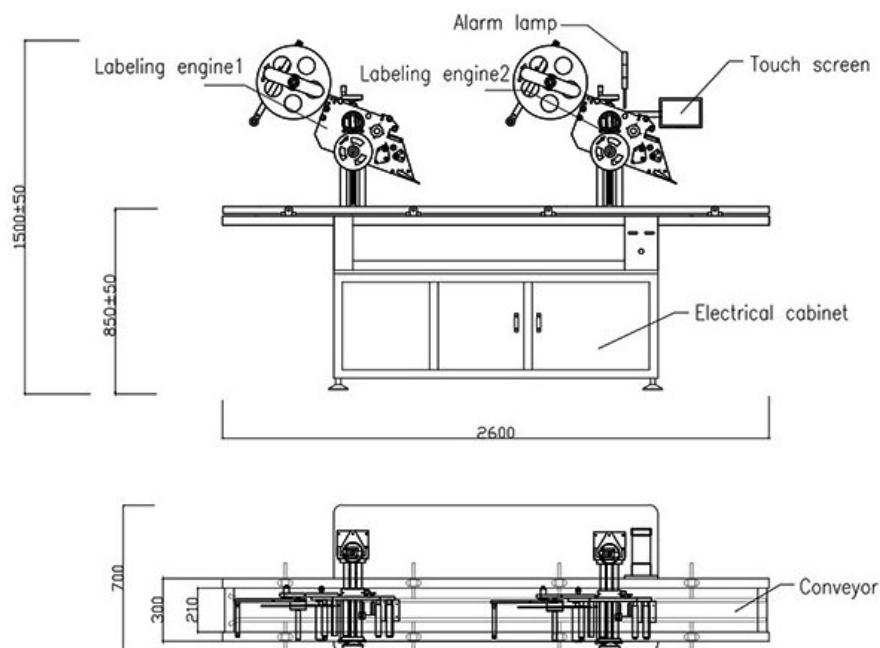

Parameters

Model	DPM-S
Driving Mode	Servo motor
Yiel (pcs/min)	10-80
Operating direction	Left or Right
Conveyor Speed (m/min)	≤40
Labeling Accuracy	±1.0 mm
Label material	Adhesive sticker, opaque or transparent label
The inner diameter of label roll	76 mm
The outer diameter of label roll	350 mm(max)
The suitable size of label	Width 15-300 mm length 15-300 mm
The suitable size of labeling objects	Can customized
Printer use air	5kg/cm ²
Voltage (In China)	AC220V 50/60HZ Single phase (Can customized as client need)