

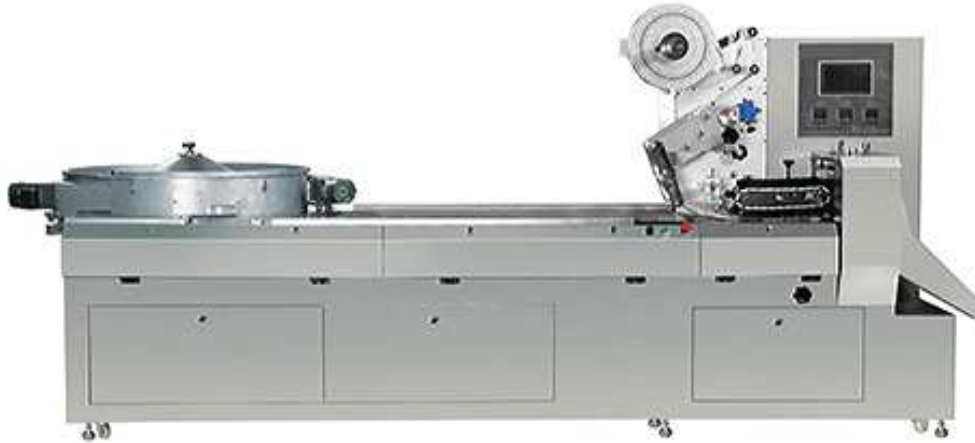

Flow Type Lollipop Packing Machine (JY-ZB900)



Application:

Ball shape Lollipop, flat lollipop, and Bonbon packing

Main Features

1. Ultra-big feeding plate with high speed feeding and surface protection.
2. Double Paper rollers, Automatic paper splicer device
3. by-directional photo slotting avoiding film-cutting error
4. Stainless steel contacting part, high level food hygiene.
5. Frequency convertor, steeples speed regulation.
6. Intelligent temperature control, complete airtight sealing.
7. Automatic candy filling device, Same with Japanese technology, ensures no empty packing.
8. Servo motors control, precise cutting point, convenient to change the packing bag length.

Technical Parameters:

Packing Speed	50-400 pcs/min
Net Weight	1200kg
Finished Bag Size	90-160mm
Outside Dimension	3520*1350*1580mm
Total Power	3.7kw
Voltage	380V,50HZ (can be customized)
Packing Shape of product	Spherical, flat lollipop etc
Adopted Product	Lollipop and similar product
Film	OPP, CPP, PET, Aluminium plating film, hot sealing film.