

# Horizontal Automatic Packaging Machine

## SDXD-18



## Horizontal Automatic Packaging Machine

The **SDXD-18** can pack powders, granules, liquids, pastes and so on with the mode of three side or four side sealed sachets. It is the packaging machine in foodstuff, pharmaceutical and cosmetic industry which is your best choice.



**Features:**

- Up to 80 pouches/min.
- bottom seal Unit
- V-sharp Standard Unit
- horizontal sealing unit
- Mechanical scissors
- Automatic material-level control system
- A Photocell tracking control system
- A PLC control system
- An automatic control system
- A product outlet system

Volumetric Cup Filing Device  
(Granule)



Auger Filler Device  
(Powder)



Gravity Dosing Device  
(Liquids)

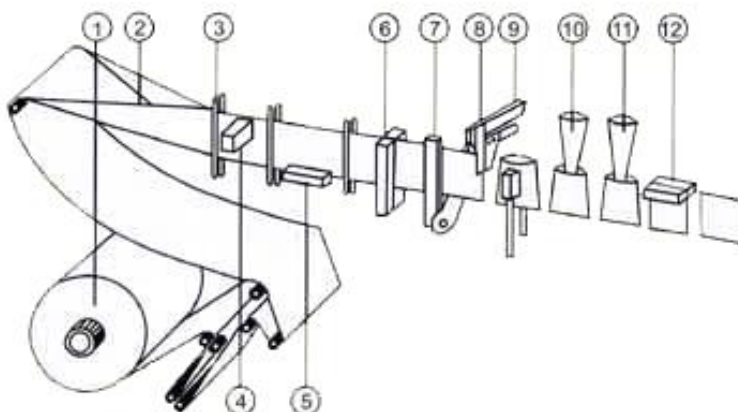

Piston Pump Filling Device  
(Creams and Pastes)

**Work Flow:**

1. Reel of material
2. "V" Formation
3. Folding guides
4. Optical sensor
5. 4TH seal
6. Vertical sealing jaws
7. Scissors
8. Pulling fingers
9. Opener
10. Discharge funnel
11. Discharge funnel
12. Upper seal

Packaging Samples:

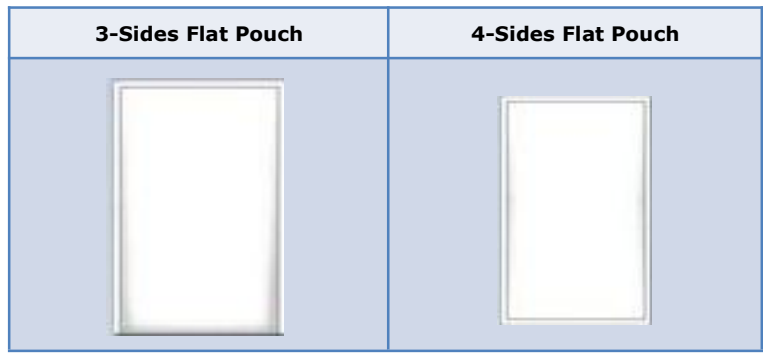

Technical Data	SDXD18
Size range of sachet	85×100~180×225mm
Volume	5~325ml
Output	40-80pouches/min
Consumption	2.05KWA
Weight	700kg
Dimensions	3200×970×2055mm(L×W×H)

SaintyCo also offer:

Encapsulation Solutions

Tablet Compression Solutions

Coating Systems

Cartoning Systems

Blister Packing Solutions

