



McBRADY ENGINEERING, INC.



<http://www.mcbradyengineering.com/>

1251 S. LARKIN AVE.
JOLIET, IL 60436

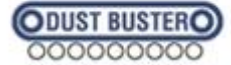

4-BELT UNSCRAMBLER

The 4-Belt Unscrambler is the ultimate solution for eliminating bottle transfers. Three progressively moving belts separate bottles, while the 4th reverse belt prevents jamming by removing excess bottles. It can be sold in conjunction with one of our bottle cleaners or sold separately to integrate into an existing bottling line.



Special Features

- **Eliminates bottle transfers** when paired with one of our bottle cleaning machines
- 4th reverse belt **prevents jamming** of bottles and **recirculates** them back into queue
- **Customizable** to nearly any desirable length, including an L-shaped dump table for **manual loading**
- Type 304 Stainless Steel construction with **FDA approved plastics**

MEMBER



SPECIFICATIONS

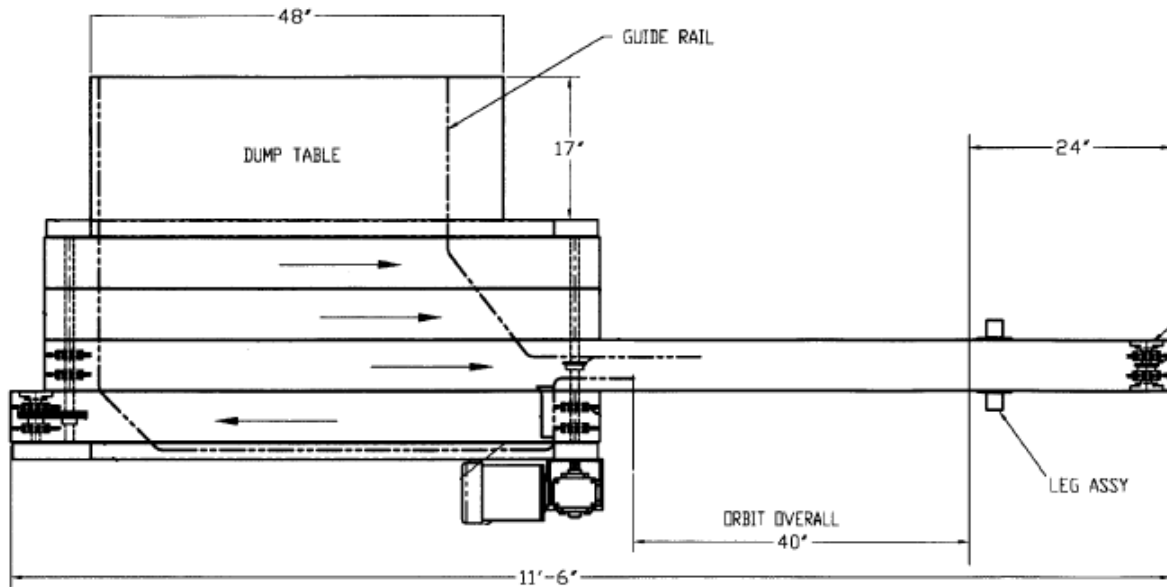

DETAILS

- Cleaner mounts to extended 6" wide discharge belt (combination eliminates transfer)
- Right and left discharge available
- Allen Bradley VFD (Electrical provided to customer's specifications)
- 4 Delrin table top chain belt conveyors (6" wide belts)
- Type 304 stainless steel frame
- Guide rails included
- Plastic lined dump station included and removable for ease of transport
- Adjustable height, +/- 2", includes ball joint feet for un-level floors

