

Cartoning Machine *for Blister*



CM 100-Cartoning Machine for Blister

The **CM-100** cartoning machine is suitable for blister package product, adjust automatic feeding structure conveniently, setup quantity of blisters on touch screen randomly. On line product feeding and detecting , leaflet fold (1-4folds) and feeding, leaflet detecting, carton opening and forming, products and leaflet pushing into carton, printing batch number, sealing carton with tuck-in or hot melt glue device. Automatically reject lacking of leaflet or product and finished product out.



Features:

- High speed: up to 6,000 cartons/h
- International famous brand of electrical component such as PLC touch screen, frequency inverters, etc.
- Adopt human-machine operation system.
- Automatically stop when machine is overload.
- Automatically reject lacking of package product and leaflet.
- Automatically display trouble, Alarm and count finished products.
- Stable performance, operation is easy.
- Options: ink jet printer, glue machine, bar code reader.

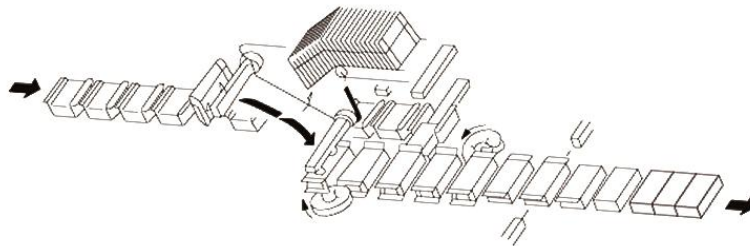

Dimensions:

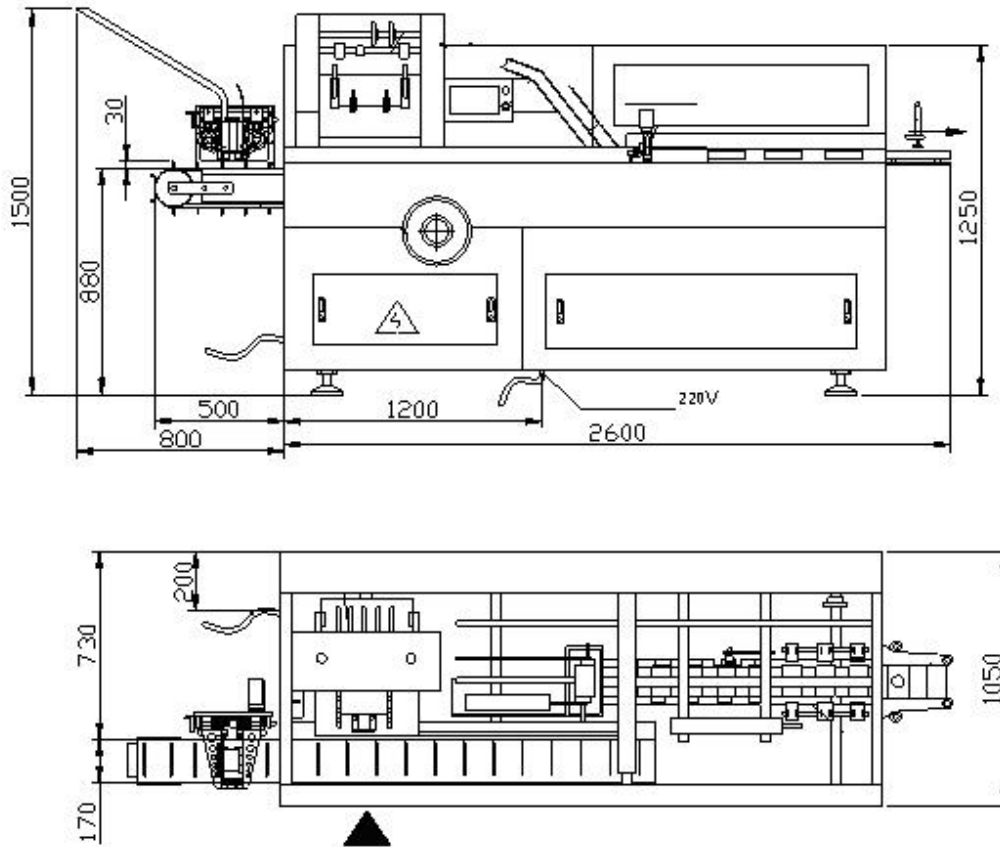

Main technical parameters		CM-100
Encasing speed		30-100cartons/min
Carton	Quality requirement	250-350g/m ²
	Dimension range(L*W*H)	(70-180) *(35-85) *(14-50)mm
Leaflet	Quality requirement	60-70g/ m ²
	Unfolded leaflet specification	(80-250) *(90-170)mm
	Fold range	1-4 fold
Compressed air	Working pressure	≥0.6mpa
	Air consumption	120-160L/min
Power supply		220/380V 50/60HZ
Motor power		0.75Kw
Machine dimension(L*W*H)		3100*1100*1550mm
Machine weight		1400kg

SaintyCo also offer:

Encapsulation Solutions

Tablet Compression Solutions

Coating Systems

Cartoning Systems

Blister Packing Solutions

