



Cone Mixer CW-MIG



Feature:

- For pharmaceutical, health food, feed, dye, seasoning, chemical raw material and other powder, granule, additive, binder, spice and other mixed projects.
- Follow the regulation of cGMP, PIC/S, GMP.
- Mixing evenly.
- Simple structure.
- Easy to clean.
- Fast speed without dead angles.
- Mixing ratio up to 1 / 10,000.
- With safety railings and safety device.

Line Graph:

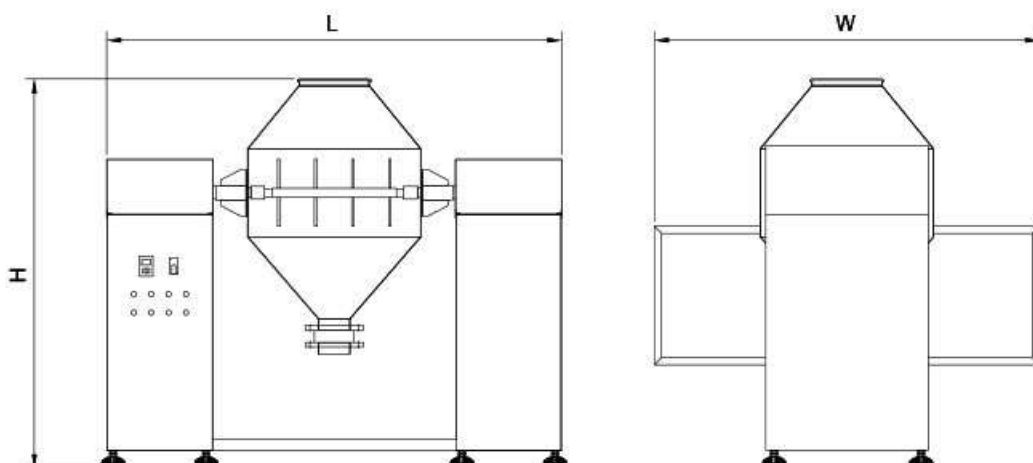

Specification:

Model CW-MIG		Unit	MIG-50	MIG-100	MIG-200	MIG-300	MIG-500
Full Capacity		L	50	100	200	300	500
Working Batch(Assuming 0.5g/c.c)		Kg	25	50	100	150	250
Discharge Height		mm	150	250	250	300	300
Discharge		mm	76	100	127	140	140
Motor		Kw	1.5	2.25	2.25	3.75	3.75
R.P.M			60	60	60	60	60
Dimensions	W	mm	1600	1800	2000	2000	2200
	H		1200	1300	1700	1700	1900
	H1		1600	1600	1700	1700	1800