

Capsule Printer Machine

CP Series

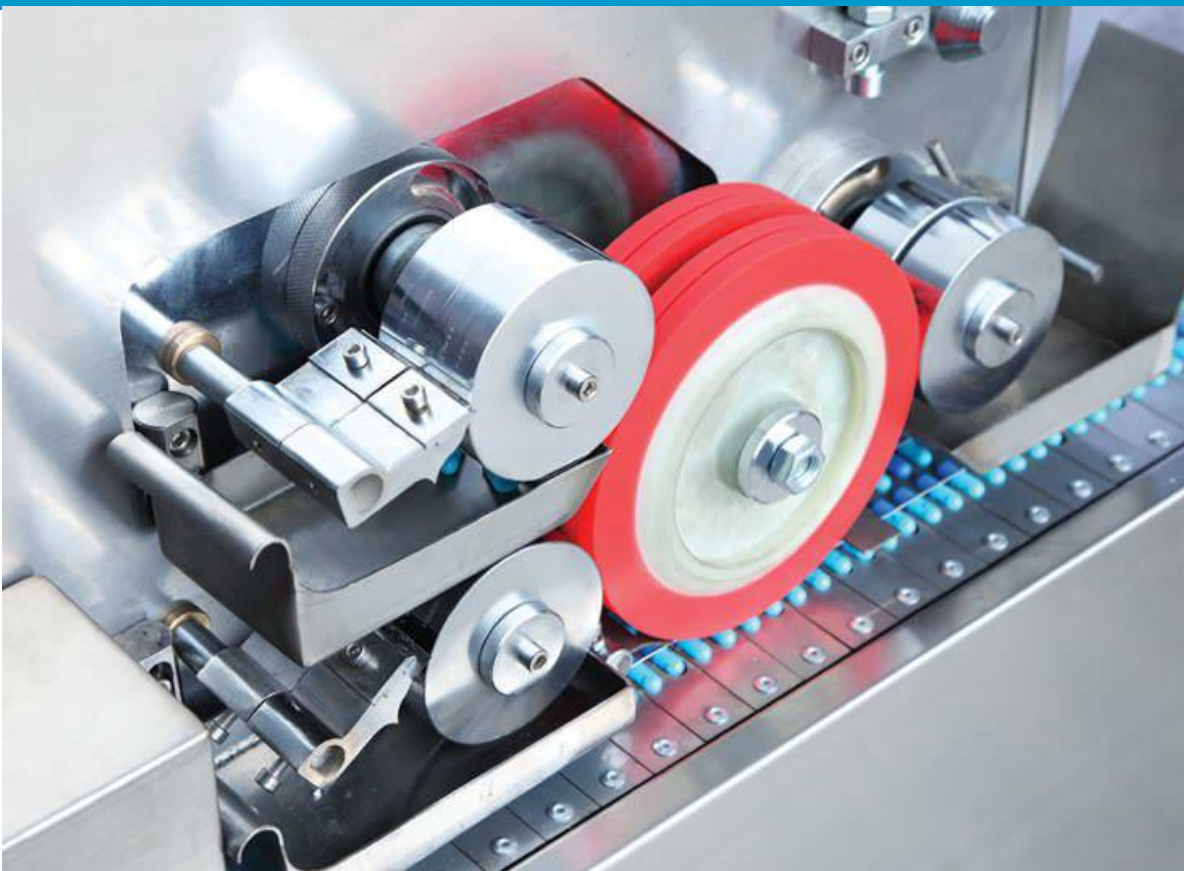

Capsule Printer Machine

CP series is designed to be used in all kinds of capsule orientation and two color printing.

CP series high speed oriented capsule two colours printer is the newest product which developed by our company. We used two technologies, one is capsule's cap and body oriented system, and the other is two colours printer. It can print character, picture and trademark according to the needs of the customers, on all kinds of capsule for circle or axial printing, Because of capsule's cap and body oriented and two colour printing at one-time, the printed effects are more varied and colourful. The single row printer can satisfy the demands of printing in small batch and many varieties, it is obvious in economic effects. It is considered as an ideal printing equipment for the capsule production and pharmaceutical enterprises.



CP-4

CP-5

Features:

- Contact parts 316L.
- Up to 180,000 pcs /hr.
- CP-4 is single row printing.
- CP-5 is double row printing.
- Capsule's cap and body oriented system.
- Two colours printing available.
- Circle or axial printing.
- Adjustable speed.
- cGMP compliant.

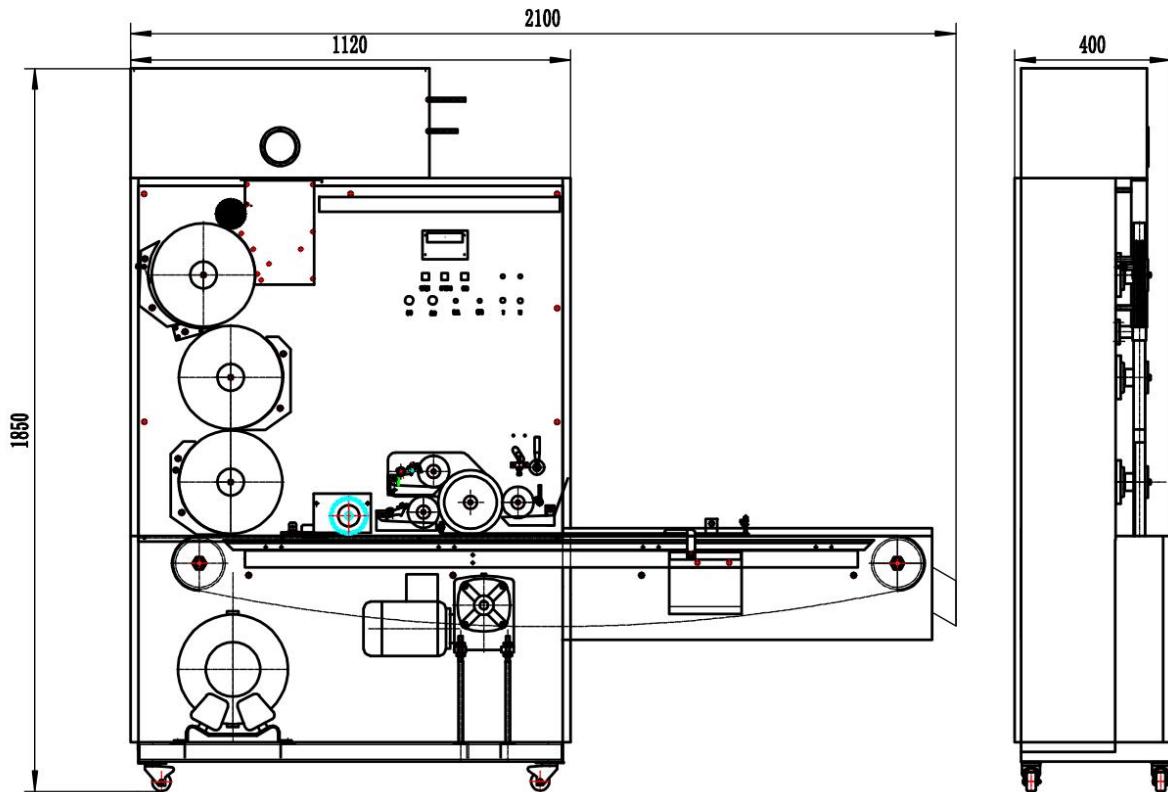

Dimensions:

Technical Data	CP-4	CP-5
Printing output	<100,000pcs/h	<180,000pcs/h
Circle scope to print on capsule	<270degree	<270degree
Power source	AC, 380V, 50H	AC, 380V, 50H
Consumption power	1.7KW	2.5 KW
Weight	400Kg	500Kg
Appearance size	2110×400× 1860mm	2110×500× 1860mm

SaintyCo also offer:

Encapsulation Solutions

Tablet Compression Solutions

Coating Systems

Cartoning Systems

Blister Packing Solutions

