

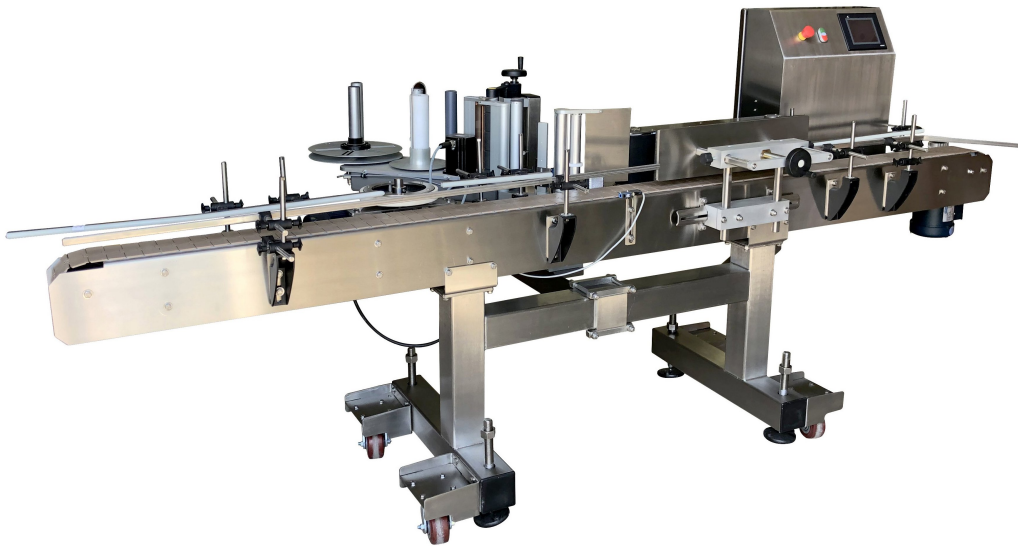

Model Tru-Labeler-W1 Wrap Around Labeler



Construction Features:

Heavy duty 304 stainless steel frame

Heavy duty casters standard

No change parts needed for a wide range of containers

Stepper driven

Labeling head for wraparound labels placed on round containers

Maximum label size: 152mm H x 300mm L (6" x 11.8")

Rolls wind #4

Maximum container width: 6"

Minimum container height: 1/2"

Conveyor: 10ft long, 4.5" wide acetal chain with speed control installed on labeler control panel

Electric and pneumatic requirements:

120 Volts, Single phase, 50/60Hz, 15 Amps.

DRAWING: TRU-L-W2

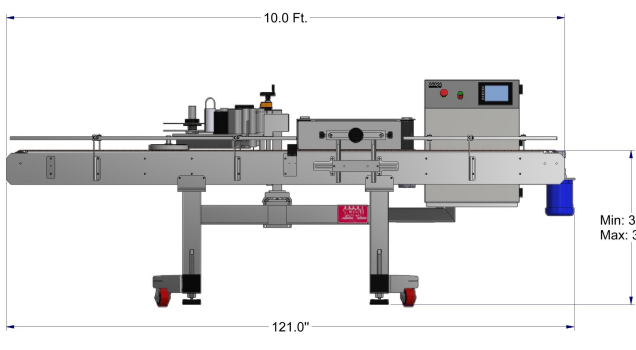
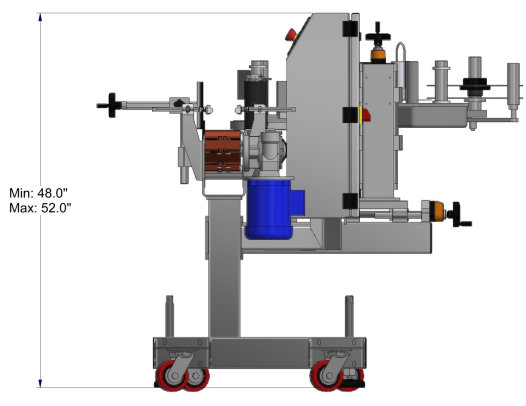
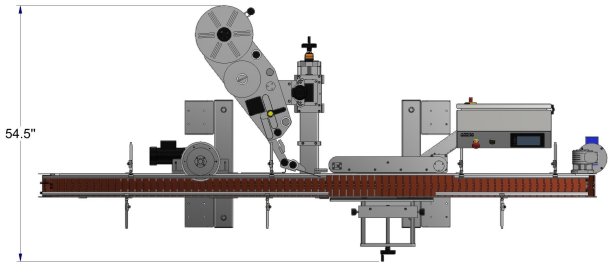

MACHINE MODEL:	Acasi Wraparound Labeler	ACASI MACHINERY INC	PAGES:	1
MACHINE CAPABILITIES:	Standard Labeler		DIM:	Inches
PRODUCTION SPEED:			BY:	Isaac
OPTIONS:	ADDITIONAL OPTIONS:		WEIGHT:	SCALE: